



Camaro Gen 6 / Cadillac CTS-V

2015-2022

PWM Fuel System Controller





Important! Must Read First

Congratulations on the purchase of the KPM Fuel System for your [2015-2022 Camaro Gen 6 and Cadillac CTS-V](#).

To ensure your fuel system is fitted correctly and operates perfectly and reliably, we advise that this kit is fitted by a KPM Fuel Systems Dealer workshop.

If you are unable to access a KPM Fuel Systems dealer, we **strongly** recommend a professional and experienced fully qualified technician to install your new fuel system.

Ask your qualified installer to contact KPM Fuel Systems on any aspect unclear in the instructions provided.

Email: support@kpmfuelsystems.com

As a wide variety of skills, procedures, special tools, and workshop equipment is needed to install this kit:

- KPM will take NO responsibility or give NO guarantees on the operation of this product for fitment not carried out by a KPM Fuel Systems dealer or experienced qualified technician.
- KPM will take NO responsibility or give NO guarantees on the operation of this product due to not fitting this kit exactly as per the instructions provided.
- Ensure correct workshop safety procedures are carried out in fitment of this kit.
- Please read **ALL** instructions before commencing fitment

Guarantee

On satisfaction that **ALL** instructions have been followed as per this document KPM will warrant this KPM PWM Fuel System Controller against any defects or faults for 12 months from the date of purchase.



Operation and Functions

The KPM Pulse Width Modulated (PWM) Fuel System Controller has been specifically designed to support up to 80 amps of continuous current draw.

This gives it the capability of running up to 4x high flow motorsport fuel pumps simultaneously and continuously.

The controller is programmed to run the fuel system at a pre-determined fuel pressure. The fuel pumps will only be run at the duty cycle required and when required. This ensures less current draw, which means less heat, improved reliability and precise tunability.

With this amount of control over fuel flow, we now have the ability to support extreme horsepower with OE level functionality.

The KPM Fuel System Controller is fully programmed from factory to perfectly suit all vehicle models and the many combinations of fuel delivery required.

The PWM Fuel System Controller has the following functions:

- 80-amp continuous current support
- Fully programmable to control up to 4 fuel pumps by means of one or all of the following inputs:
 - Fuel pressure, MAP, MAF, Throttle position. *
- Fully programmable OE factory PWM input, piggy back control
- Fully programmable pump output and pump staging*
- Fully programmable system pressure settings*
- Multiple options for safety settings and pump control*
- Multiple gauge and warning light outputs*
- Advanced low temperature electronic circuits for robust motorsport and long-term reliability
- Supplied with EMI shielded high amperage wiring and connector kit to block out interference with other vehicle electronic modules and devices.
- LED on controller for visual system pass and fault code readout.
- Fully modular fitment to all KPM Fuel Systems

[*To re-program this function please contact KPM Fuel Systems.](#)

The KPM PWM Fuel System Controller will be supplied pre-programmed to exactly suit the model of your vehicle and the level of KPM fuel system purchased.

There is nothing to do, just follow the wiring instructions, plug in the connectors and start the car. Simple! The controller will do the rest.



Vehicle and Fuel System Specific Operation and Function **Vehicles with a Factory FSCM (Fuel System Control Module)** **(Camaro Gen 6/Cadillac CTS-V 2015-2022)**

The KPM PWM Fuel System Controller comes complete with wiring to be connected to the vehicles factory FSCM to read the OE signals. The KPM PWM Fuel System Controller uses the OE signals from the FSCM to calculate the correct current required to run the pumps accordingly.

The KPM PWM can also be programmed utilizing the OE fuel system programming tables.

KPM1500 – Primary Module only

Primary module fuel pumps are always running and duty cycle input will vary on load demand. As an example, at idle both the pumps may be running at approx. 40% duty cycle and at part load they may be at 55% and then ramping up to full load at 80% duty cycle.

This cycle will continue as load increase and decreases while keeping fuel pressure as per OE settings.

KPM2200/2700 - Primary and Secondary Module

On every start-up, the secondary module pump/s are primed for 10 seconds only. This ensures the circuit is tested and that the secondary module pump/s are always ready and primed when required for high load operation.

Primary module fuel pumps are always running and duty cycle input will vary on load demand. As an example, at idle both the pumps may be running at approx. 40% duty cycle and at part load they may be at 55%.

When the primary module reaches 90% duty cycle, the fuel controller will then turn on a *duty cycle signal* to the secondary module fuel pump and continue to ramp duty cycle up or down accordingly as required.

When load decreases and the controller see's the primary module requiring a duty cycle of only 80% it will then slowly ramp down the *duty cycle signal* to the secondary module and eventually turn it off. This cycle will continue as load increase and decreases while keeping fuel as per OE settings.



Important

This fuel system is engineered to operate perfectly as a complete system, when used with all components as supplied only by KPM Fuel Systems.

Depending on the level of KPM Fuel System you have purchased, included in the kit will be the following;

- 1) KPM PWM Fuel System Controller - (for precise electronic control over fuel module operation)
 - 2) KPM Plug and Play EMI safe wiring kit (for correct, reliable and safe current supply)
- KPM Fuel Systems will take NO responsibility for the operation of this fuelsystem if any of the components listed are not utilized with this package.
 - KPM Fuel Systems will take NO responsibility for the operation of this fuel system if any of the components listed are replaced with a non-KPM approved component.

Dismantle vehicle for fitment

- 1) Remove your Flat Tire Repair Kit and foam surrounding located in the spare tire well in the trunk.



- 2) Remove Right-hand (RH) inner trunk liner trimming/s to expose the battery and inside trunk rear parcel shelf area.





3) Remove the rear seat base to access the rear seat LH and RH floor.

- **If the vehicle has already** been fitted with a KPM Fuel Module, you will find that the RH floor cap has been removed and has a KPM fuel module wiring loom and grommet fitted.
 - Disconnect the wiring at the fuel module, by unplugging the grey Anderson connectors.
 - Proceed to remove and discard the rest of the previous KPM wiring and relay that leads to the battery (this will be replaced with the new #CAM6-3 wiring supplied).
- **If the vehicle is now** being fitted with the KPM Fuel Module/s you will need to carefully pop out the corresponding sealing caps (1 or 2) to allow access for the KPM Fuel Module/s wiring loom fitment.

See the fitment instructions on your relevant [KPM 1500HP or 2200/2700HP Fuel System](#)

PWM Fuel Controller Mounting

- 1) Place your PWM controller in the correct position as pictured and while doing so use a marker pen to mark the 4 holes required for drilling.
- 2) Drill the 4 marked holes carefully with a 3.5mm drill bit and use the supplied screws to mount into position.
- 3) Be sure to mount the PWM controller small black earth wire/eyelet and screw down into one of the appropriate holes.





PWM Fuel Controller Wiring

- 1) Depending on the level of KPM Fuel system you have installed – either KPM1500 HP or KPM2200 / 2700 HP you will need to follow the appropriate wiring diagram below.
- 2) All Anderson wiring connectors are color coded to ensure correct connection orientation as per wiring diagram.
- 3) Route the supplied wiring as per your specific fuel kit and as per appropriate wiring diagram and pictures listed below.

*Note – The PWM Fuel controller wiring is made with a stainless-steel shielding incorporated. This is to prevent EMI (electro-magnetic interference) from disrupting other vehicle systems and control modules. It is very important that the grounding wire connectors that link together every section of the supplied wiring are connected as per wiring diagram.

PWM 1500 HP

Camaro Gen6 2016-2021
PWM and Wiring Schematics

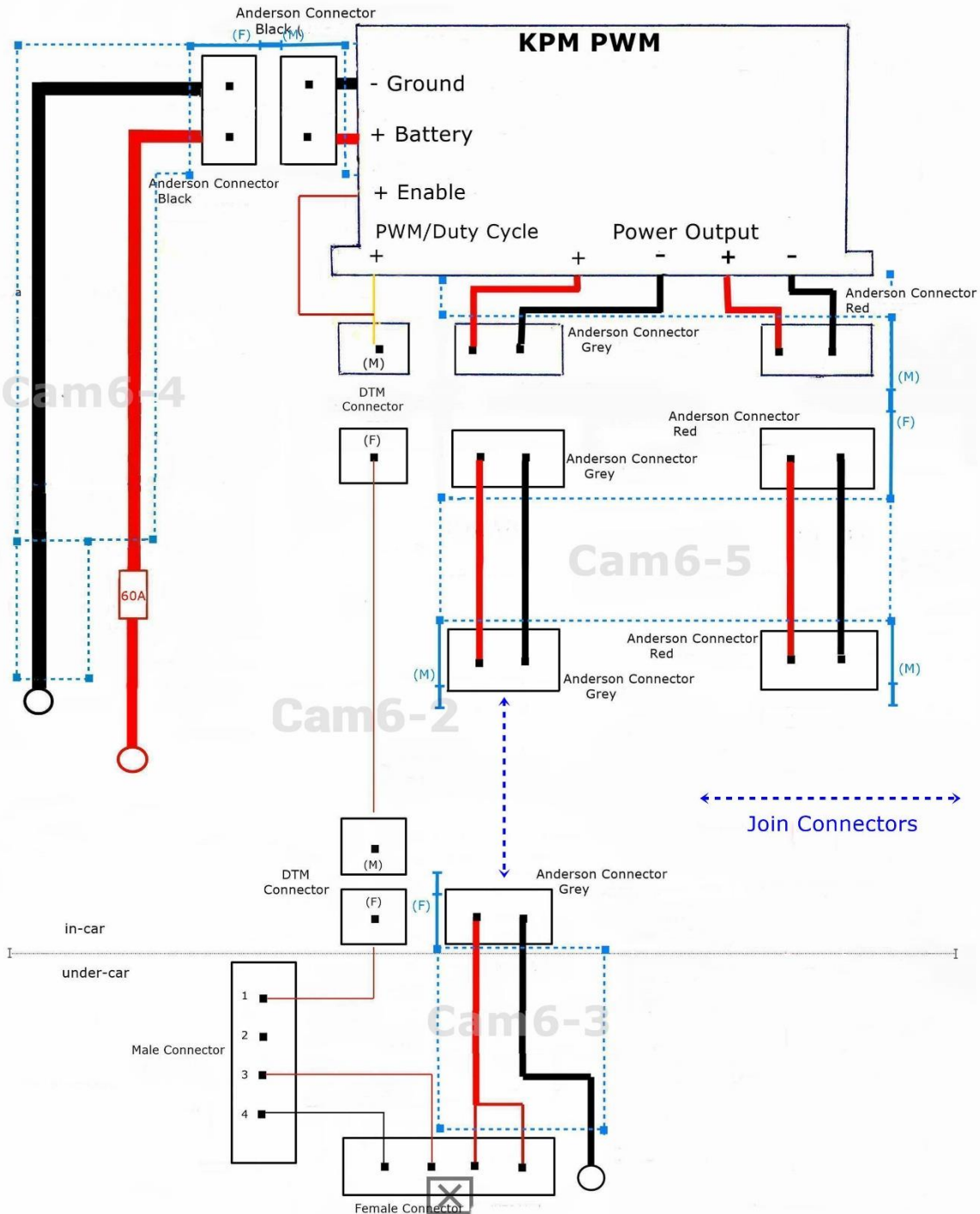

PWM 2200 HP & 2700 HP

Camaro Gen6 2016-2021
PWM and Wiring Schematics

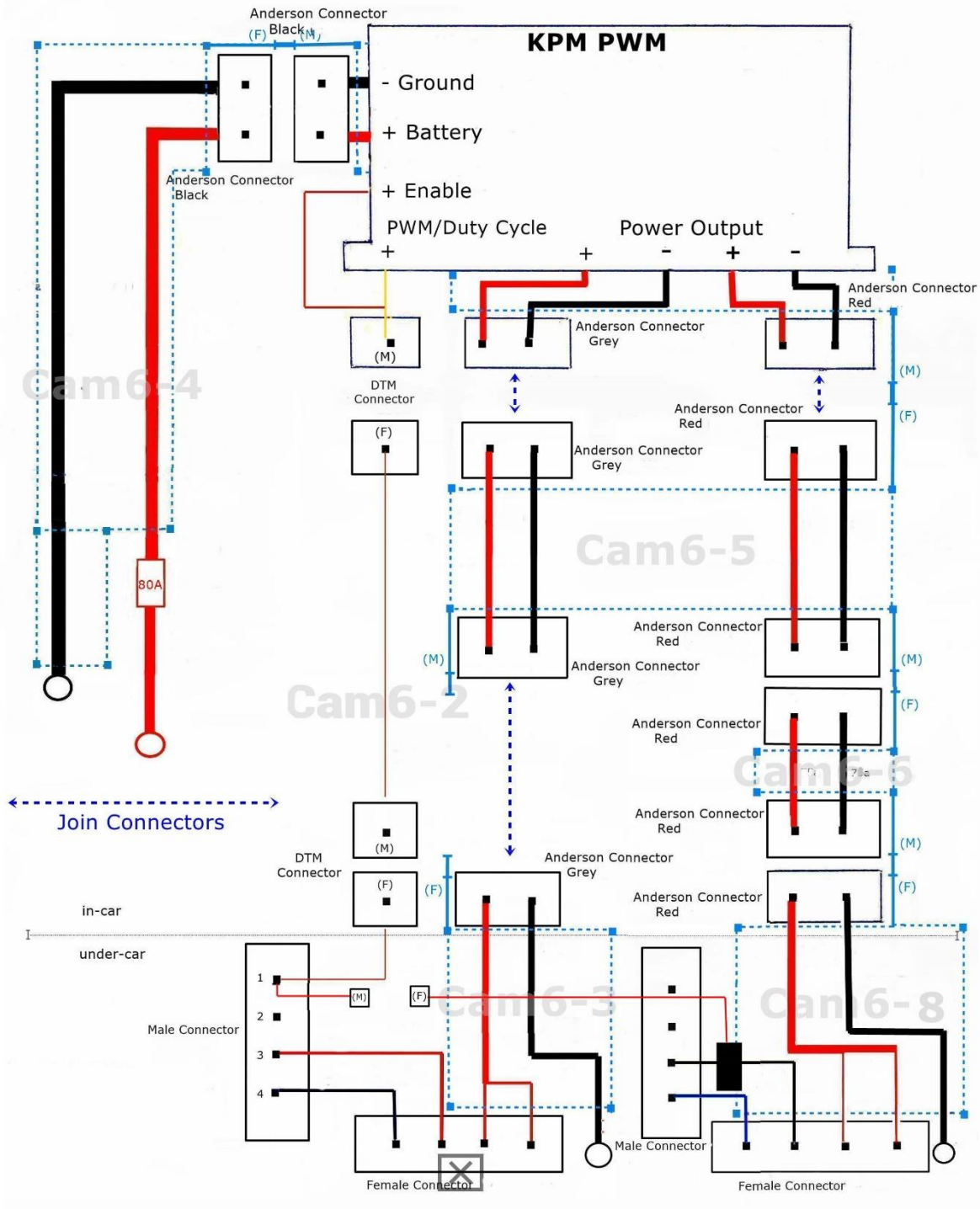

Wire and cable routing

- 1) Depending on the level of fuel system you have installed, you will have either one or two separate fuel modules that require wiring to the battery and PWM Fuel controller.
- 2) The only difference between a single fuel module wiring and a dual fuel module wiring kit is that the dual module wiring kit will contain an extra cable (Cam6-6) that runs from the main cable (Cam6-5) to the second fuel module.

1500HP Single fuel module routing



2200HP/2700HP Dual fuel module routing

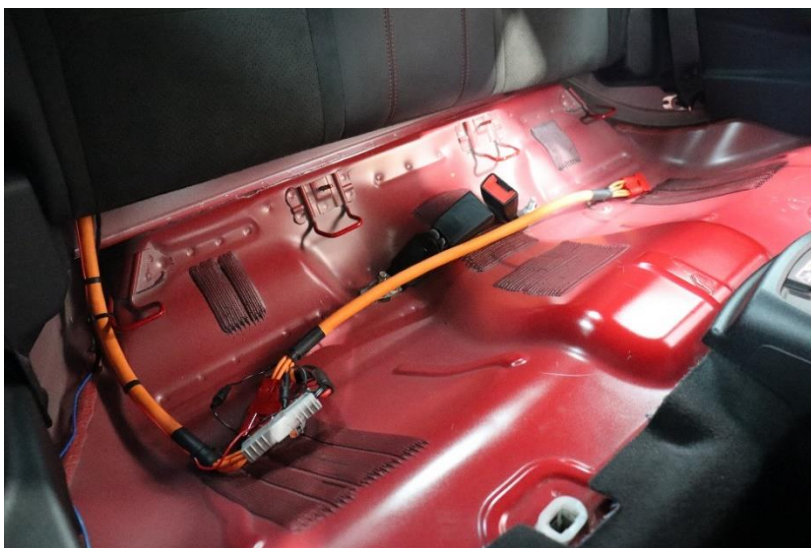

KPM FUEL SYSTEMS

- 3) From in the cabin, follow the factory loom around to the side of the rear seat.
- 4) Locate the gap between the RH rear seat and body area to be able to feed the new loom section #Cam6-5 into the trunk toward the KPM PWM Fuel System Controller.



- 5) Depending on the level of KPM fuel system you have fitted, connect the grey Anderson connectors (1500 HP Fuel system) or both the grey and red Anderson connectors (2200/2700HP Fuel system) at the PWM controller.
- 6) Connect the black Anderson connectors at the PWM controller to the black Anderson connectors on the #Cam6-4 wiring section.
- 7) Route the #Cam6-4 wiring section to the battery. Mount the supplied fuse box and relay securely on an appropriate surface near the battery and secure the loom.
- 8) Neatly route the loom as shown and secure all the wiring.

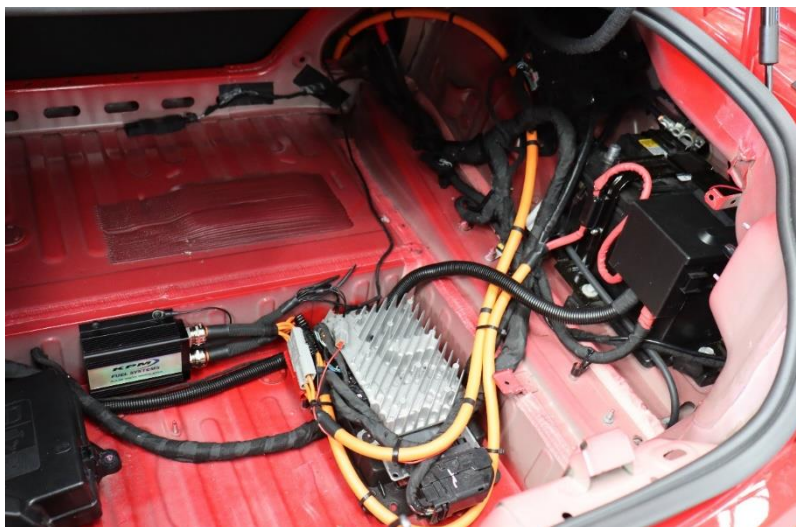

Start Up & Checks.

- 1) When you are satisfied your PWM Fuel Controller is fully installed, you are now ready to start your vehicle.
- 2) Simply start and run the car as normal.
- 3) On one end face of your KPM PWM Fuel System Controller you should see a green LED flashing approximately once per second. This means that all systems are working normally.

Note* If your LED is not flashing green approximately once per second or is flashing any other color, you may have a system problem. Please contact KPM Fuel Systems.

Refit interior

- 1) You can now refit your rear seat base.
- 2) Your Flat Tire Repair Kit foam surround will require modifying by slightly shortening it to make room for the PWM Fuel System controller as pictured below.



- 3) Refit the RH inner trunk liner trimming/s

Congratulations, you have successfully fit the KPM PWM Fuel System Controller.

IMPORTANT INFORMATION

KPM strongly recommends that you have your engine tune checked by a professional tuning workshop!

Depending on the previous fuel system your vehicle has been tuned to, your car may run differently with the new KPM Fuel System pressure and extra supply.

This can cause rich or lean fuel mixtures and possibly be detrimental to your engine!

It is your responsibility to have your vehicle checked and/or re-tuned by specialist methods to ensure correct fueling and engine safety and reliability.

It is your responsibility to have your vehicle checked and/or re-tuned by specialist methods to ensure any fault codes in the vehicles electronic management system/s are corrected.