



2013-2017 CHEVROLET SS
PWM FUEL SYSTEM CONTROLLER





Important! Must Read First

Congratulations on the purchase of a KPM Fuel System for your [2013-2017 Chevrolet SS](#).

To ensure your fuel system is fitted correctly and operates perfectly and reliably, we advise that this kit is fitted by a KPM Fuel Systems Dealer workshop.

If you are unable to access a KPM Fuel Systems dealer, we **strongly** recommend a professional and experienced fully qualified technician to install your new fuel system.

Ask your qualified installer to contact KPM Fuel Systems on any aspect unclear in the instructions provided.

Email: support@kpmfuelsystems.com

As a wide variety of skills, procedures, special tools, and workshop equipment is needed to install this kit:

- KPM will take NO responsibility or give NO guarantees on the operation of this product for fitment not carried out by a KPM Fuel Systems dealer or experienced qualified technician.
- KPM will take NO responsibility or give NO guarantees on the operation of this product due to not fitting this kit exactly as per the instructions provided.
- Ensure correct workshop safety procedures are carried out in fitment of this kit.
- Please read **ALL** instructions before commencing fitment

Guarantee

On satisfaction that **ALL** instructions have been followed as per this document KPM will warrant this KPM Fuel System against any defects or faults for 12 months from the date of purchase.



Operation and Functions

The KPM Pulse Width Modulated (PWM) Fuel System Controller has been specifically designed to support up to 80 amps of continuous current draw.

This gives it the capability of running up to 4x high flow motorsport fuel pumps simultaneously and continuously.

The controller is programmed to run the fuel system at a pre-determined fuel pressure. The fuel pumps will only be run at the duty cycle required and when required. This ensures less current draw, which means less heat, improved reliability and precise tunability.

With this amount of control over fuel flow, we now have the ability to support extreme horsepower with OE level functionality.

The KPM Fuel System Controller is fully programmed from factory to perfectly suit all vehicle models and the many combinations of fuel delivery required.

The KPM Fuel System Controller has the following functions:

- 80-amp continuous current support
- Fully programmable to control up to 4 fuel pumps by means of one or all of the following inputs:
 - Fuel pressure, MAP, MAF, Throttle position. *
- Fully programmable OE factory PWM input, piggy back control
- Fully programmable pump output and pump staging*
- Fully programmable system pressure settings*
- Multiple options for safety settings and pump control*
- Multiple gauge and warning light outputs*
- Advanced low temperature electronic circuits for robust motorsport and long-term reliability
- Supplied with EMI shielded high amperage wiring and connector kit to block out interference with other vehicle electronic modules and devices.
- LED on controller for visual system pass and fault code readout.
- Fully modular fitment to all KPM Fuel Systems

* [To re-program this function please contact KPM Fuel Systems.](#)

The KPM PWM Fuel System Controller will be supplied pre-programmed to exactly suit the model of your vehicle and the level of KPM fuel system purchased.

There is nothing to do, just follow the wiring instructions, plug in the connectors and start the car. Simple! The controller will do the rest.



Vehicle and Fuel System Specific Operation & Function

Vehicles with a Factory FSCM (Fuel System Control Module)

(Chevrolet SS 2013-2017)

The KPM Fuel System Controller comes complete with wiring to be connected to the vehicles factory FSCM to read the OE signals. The KPM Fuel System Controller uses the OE signals from the FSCM to calculate the correct current required to run the pumps accordingly. The KPM PWM can also be programmed utilizing the OE fuel system programming tables.

KPM1500 – Primary Module Only

Primary module fuel pumps are always running and duty cycle input will vary on load demand. As an example, at idle both the pumps may be running at approx. 40% duty cycle and at part load they may be at 55% and then ramping up to full load at 80% duty cycle.

This cycle will continue as load increases and decreases while keeping fuel pressure at a constant pre-programmed 400 kPa.

KPM2200 - Primary and Secondary Module

On every start-up, the secondary module pump/s are primed for 10 seconds only. This ensures the circuit is tested and that the secondary module pump/s are always ready and primed when required for high load operation.

Primary module fuel pumps are always running and duty cycle input will vary on load demand. As an example, at idle both the pumps may be running at approx. 40% duty cycle and at part load they may be at 55%.

When the primary module reaches 90% duty cycle, the fuel controller will then turn on a *duty cycle signal* to the secondary module fuel pump and continue to ramp duty cycle up or down accordingly as required.

When load decreases and the controller see's the primary module requiring a duty cycle of only 80% it will then slowly ramp down the *duty cycle signal* to the secondary module and eventually turn it off. This cycle will continue as load increases and decreases while keeping fuel pressure at a constant pre-programmed 400 kPa.



Important

This fuel system is engineered to operate perfectly as a complete system, when used with all components as supplied only by KPM Fuel Systems.

Depending on the level of KPM Fuel System you have purchased, included in the kit will be the following;

- 1) KPM PWM Fuel System Controller - (for precise electronic control over fuel module operation)
 - 2) KPM Plug and Play EMI safe wiring kit (for correct, reliable and safe current supply)
- KPM Fuel Systems will take NO responsibility for the operation of this fuelsystem if any of the components listed are not utilized with this package.
 - KPM Fuel Systems will take NO responsibility for the operation of this fuel system if any of the components listed are replaced with a non-KPM approved component.

Dismantle Vehicle for Fitment

- 1) Remove LH inner trunk liner trimming/s to expose the battery and inside trunk rear parcel shelf area.



- 2) Remove rear seat base to access the fuel pump module wiring on the RH Floor area.
- 3) **If the vehicle has already** been fitted with a KPM Fuel Module, you can disconnect the wiring at the fuel module by unplugging the grey Anderson connectors.
 - a. Proceed to remove and discard the rest of the previous KPM wiring and relay that leads to the battery (this will be replaced with the new #Com4 wiring supplied).
- 4) **If the vehicle is now** being fitted with the KPM Fuel Module/s you will now have access to the large grommet/s on the RH floor area where the standard factory looms runs through to the fuel tank. At this point you will need to read the instruction section on the relevant **KPM Fuel Module Fitment**.



PWM Fuel Controller Mounting

- 1) Place your PWM controller in the correct position as pictured and while doing so use a marker pen to mark the 4 holes required for drilling.



- 2) Drill the 4 marked holes carefully with a 3.5mm drill bit and use the supplied screws to mount into position.
- 3) Be sure to mount the PWM controller small black earth wire/eyelet and screw down into one of the appropriate holes.





PWM Fuel Controller Wiring

- 1) Depending on the level of KPM Fuel system you have installed – either KPM1500 HP or KPM2200 you will need to follow the appropriate wiring diagram below.
- 2) All Anderson wiring connectors are color coded to ensure correct connection orientation as per wiring diagram.
- 3) Route the supplied wiring as per your specific fuel kit and as per appropriate wiring diagram and pictures listed below.

*Note – The PWM Fuel controller wiring is made with a stainless-steel shielding incorporated. This is to prevent EMI (electro-magnetic interference) from disrupting other vehicle systems and control modules. It is very important that the grounding wire connectors that link together every section of the supplied wiring are connected as per wiring diagram.

1500 HP KPM FUEL SYSTEM

Chevrolet SS 2013-2017
Wiring Schematics

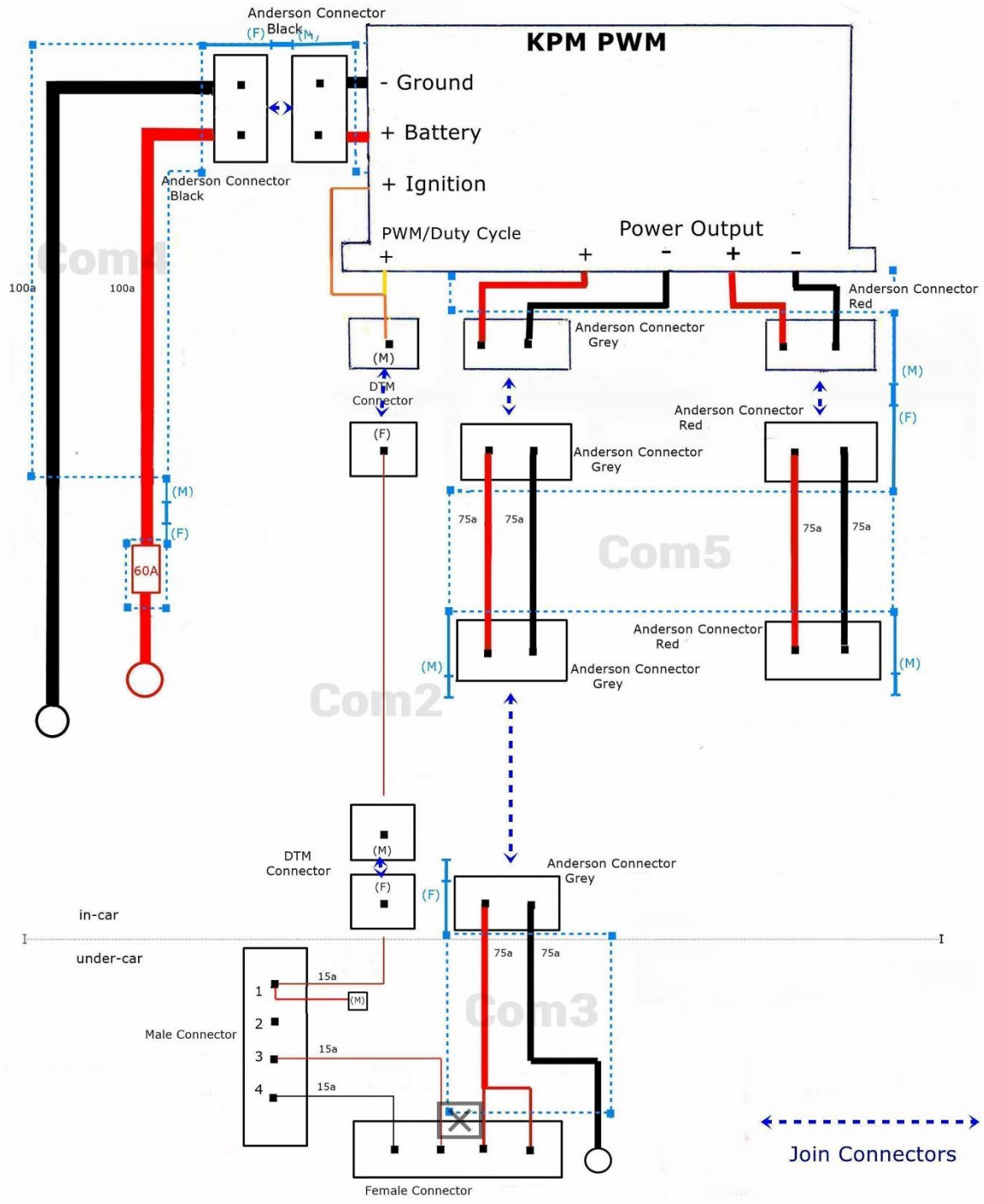

2200 HP KPM FUEL SYSTEM

PWM and Wiring Schematics

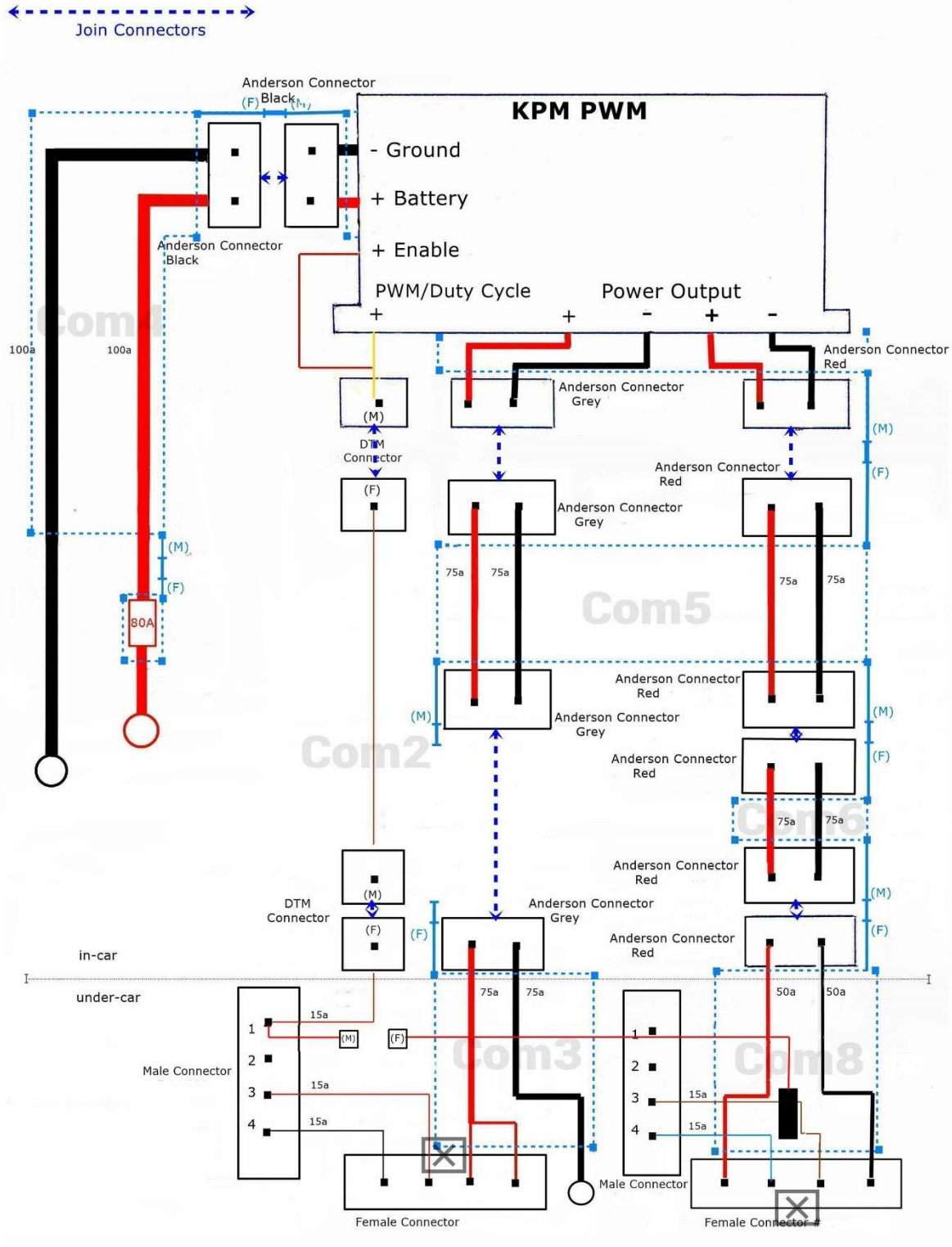

Wire and cable routing

- 1) Depending on the level of fuel system you have installed, you will have either one or two separate fuel modules that require wiring to the battery and PWM Fuel controller.
- 2) The only difference between a single fuel module wiring and a dual fuel module wiring kit is that the dual module wiring kit will contain an extra cable (Com6) that runs from the main cable (Com5) to the second fuel module.



KPM FUEL SYSTEMS

- 3) The pictures below will best show the routing for the cables and wires for all fuel systems.



- 4) Route the #Com4 wiring section to the battery. Mount the supplied fuse box securely on an appropriate surface near the battery and secure the loom

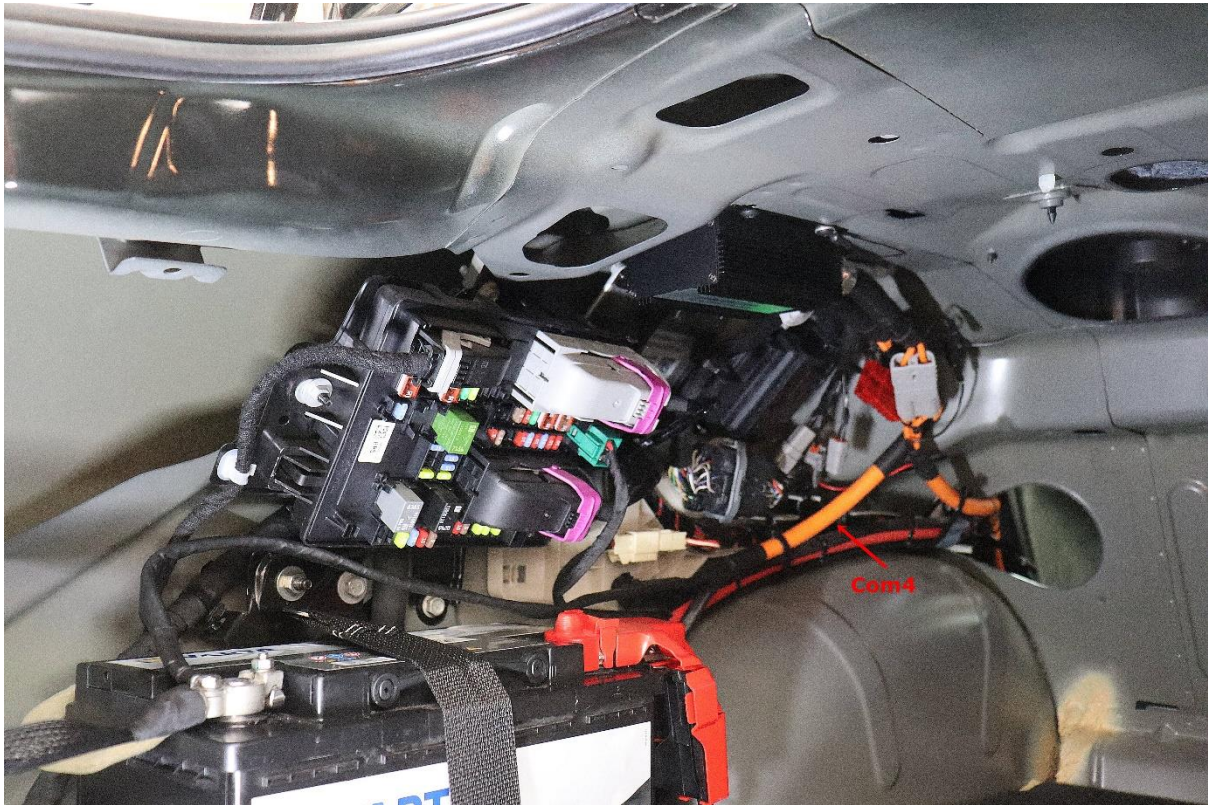

- 5) Neatly and securely fasten all cables as pictured with cable ties.

Start Up & Checks.

- 1) When you are satisfied your PWM Fuel Controller is fully installed, you are now ready to start your vehicle.
- 2) Simply start and run the car as normal.
- 3) On one face end of your KPM Fuel System Controller you should see a green LED flashing approximately once per second. This means that all systems are working normally.

Note* If your LED is not flashing green approximately once per second or is flashing any other color, you may have a system problem. Please contact KPM Fuel Systems.

Refit interior

- 1) You can now refit your rear seat base.
- 2) Depending on the exact location that you have installed the KPM Fuel controller, you may need to slightly trim the inner trunk liner as pictured to ensure a neat and finished fit.



Congratulations, you have successfully fit the KPM PWM Fuel System Controller.

IMPORTANT INFORMATION

KPM strongly recommends that you have your engine tune checked by a professional tuning workshop!

Depending on the previous fuel system your vehicle has been tuned to, your car may run differently with the new KPM Fuel System pressure and extra supply.

This can cause rich or lean fuel mixtures and possibly be detrimental to your engine!

It is your responsibility to have your vehicle checked and/or re-tuned by specialist methods to ensure correct fueling and engine safety and reliability.

It is your responsibility to have your vehicle checked and/or re-tuned by specialist methods to ensure any fault codes in the vehicles electronic management system/s are corrected.