

Ford F150 2015 onwards 1500HP Fuel Module





Important! Must Read First

Congratulations on the purchase of a KPM Fuel System for your [Ford F150](#).

To ensure your fuel system is fitted correctly and operates perfectly and reliably, we advise that this kit is fitted by a KPM Fuel Systems Dealer workshop.

If you are unable to access a KPM Fuel Systems Dealer, we [strongly](#) recommend a professional and experienced fully qualified technician to install your new fuel system.

Ask your qualified installer to contact KPM Fuel Systems on any aspect not clear in the instructions provided.

Email: support@kpmfuelsystems.com

As a wide variety of skills, procedures, special tools, and workshop equipment is needed to install this kit:

- KPM will take NO responsibility or give NO guarantees on the operation of this product for fitment not carried out by a KPM Fuel Systems dealer or experienced qualified technician.
- KPM will take NO responsibility or give NO guarantees on the operation of this product due to not fitting this kit exactly as per the instructions provided.
- Ensure correct workshop safety procedures are carried out in fitment of this kit.
- Please read [ALL](#) instructions before commencing fitment.

Guarantee

On satisfaction that ALL instructions have been followed as per this document KPM will warrant this KPM Fuel System against any defects or faults for 12 months from the date of purchase.



Important

This fuel system is engineered to operate perfectly as a complete system, when used with all components only as supplied by KPM Fuel Systems.

Depending on the level of KPM Fuel System you have purchased, included in the kit will be the following;

KPM Fuel Module x 1 - Primary (for increased flow and capacity)

- KPM Fuel Systems will take NO responsibility for the operation of this fuel system if any of the components listed are not utilized with this package.
- KPM Fuel Systems will take NO responsibility for the operation of this fuel system if any of the components listed are replaced with a non-KPM approved component.
- KPM will take NO responsibility for the operation of this fuel system if used on a vehicle NOT fully retrofitted for E85 Ethanol or flex fuel.

Note: E85 Ethanol is highly corrosive on many components.

Please be aware that if your car is NOT built for E85 Ethanol from manufacturer, it may be possible that components NOT supplied by KPM Fuel Systems will also need to be replaced or suited for E85 Ethanol. Examples of some possible non-compatible components - are fuel injectors, fuel filters, fuel lines, rubber hoses, fittings etc.

All KPM Fuel System components are 100% ethanol and petrol compatible. Fuel filter supplied in this kit however is NOT ethanol compatible and if you wish to use ethanol you must find a suitable filter.



Before Dismantling

- You will need to reduce residual fuel pressure in the fuel system to 0 kPa to enable disconnection of fuel lines.
- You can do this by removing the fuel pump fuse and running the engine until fuel pressure drops to 0 kPa.
- Disconnect the Battery.

Standard Fuel Module Removal

- 1) Drain fuel tank.
- 2) Disconnect fuel lines and vapor lines on top of fuel tank.
- 3) Remove fuel tank from vehicle.
- 4) Remove the retaining ring holding the fuel module to the tank with the correct tool.
- 5) Carefully lift the module completely from the fuel tank.

KPM Fuel Module Fitment 1500HP

You will need to remove the fuel sender unit from the standard fuel module for fitment to the upgraded KPM Fuel Module.

- 1) Cut electrical connector from sender unit and crimp supplied barrel joiners to attach to sender wires on fuel pump module lid.
- 2) Carefully lower the fuel module into the fuel tank.
- 3) With the fuel pump module sitting in the tank, slide it toward the rear of the opening to allow access for the sender unit to be placed in.
- 4) Lower sender unit into available space alongside the pump module
- 5) Slide the sender unit base up the bracket and clip into position. Ensure wires are clipped into bracket.
- 6) Ensure tank O ring and sealing surfaces are clean of debris. Compress fuel pump module lid and attach retaining ring. Use suitable tool to lock retaining ring.
- 7) Connect fuel filter and lines and F150-3 wiring harness as shown
Ensure filter is fitted in the correct direction
- 8) Re fit fuel tank to vehicle.

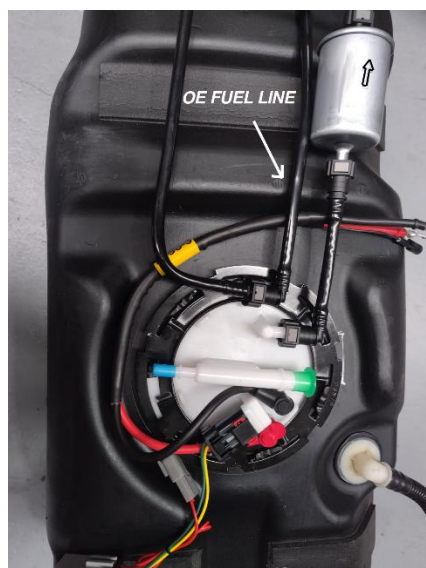

Wiring/Relay Fitment (Schematic Diagram Attached)

IMPORTANT INFORMATION

Due to the two Bosch Racing fuel pumps fitted to the KPM1500HP fuel module, the vehicles Fuel Pump Driver Module (FPDM) is bypassed with this wiring kit.

This is due to the fuel pumps drawing an increased amperage much higher than the (FPDM) is designed for. Should you want to retain the OE fuel pressures and control that the FPDM offers, you will need the additional KPM PWM Fuel Control Module Kit.

Inside vehicle

This shows where the wiring sections will run from the battery, through the inside of the vehicle and to the tank on a LONG wheelbase variant. SHORT wheelbase variants will need to locate an appropriate location to run wiring through the floor.

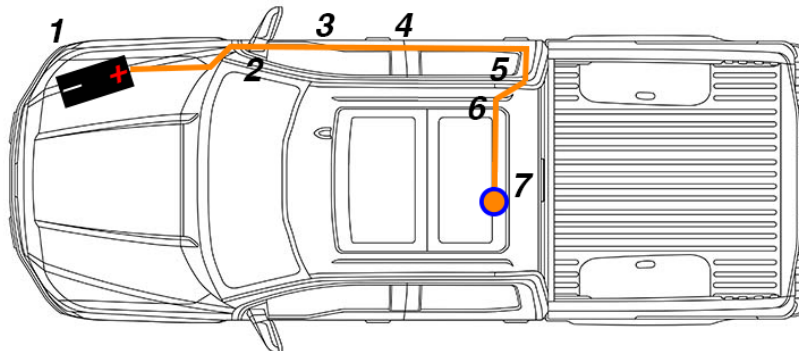

- 1) Starting at the battery, attach wiring section F150-1 to battery
And start to feed through grommet at firewall.



KPM FUEL SYSTEMS

- 2) After removing passenger side kick panel, continue feeding wiring through and follow the OE wiring loom down to the floor to the carpet seam under the scuff panels.

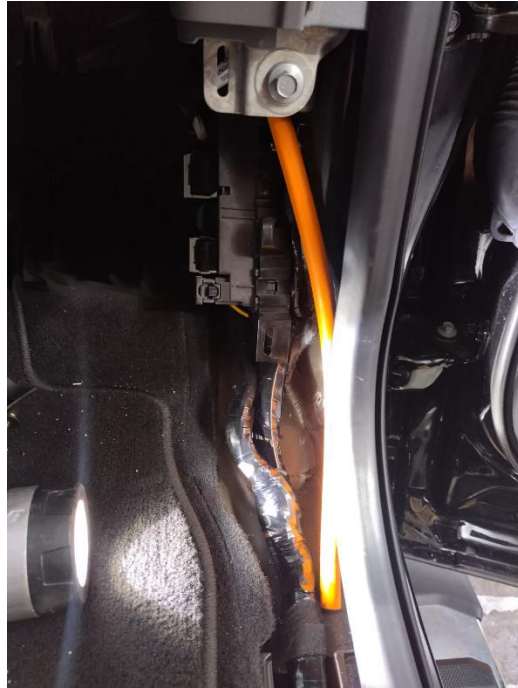

- 3) Unclip the trim at the base of the carpet and the scuff panels and feed wiring towards rear of vehicle underneath the clips.



- 4) Continue feeding wiring sections toward the rear of the vehicle underneath the trim panels.



- 5) Route wiring under the rear most trim panel and cross wiring over to beneath the rear seat and past jack and tool kit.



KPM FUEL SYSTEMS

- 6) Feed wiring sections beneath the rear seat and towards the driver's side of the vehicle.



- 7) The F150-1 will stop here. Leave the wiring at this point inside for now. Clip terminals into Black Anderson connector (black -) (red +)
[Picture shown below for position reference](#)



Underneath vehicle

LONG wheelbase shown. For Short wheelbase find appropriate location to run wiring through cabin floor.

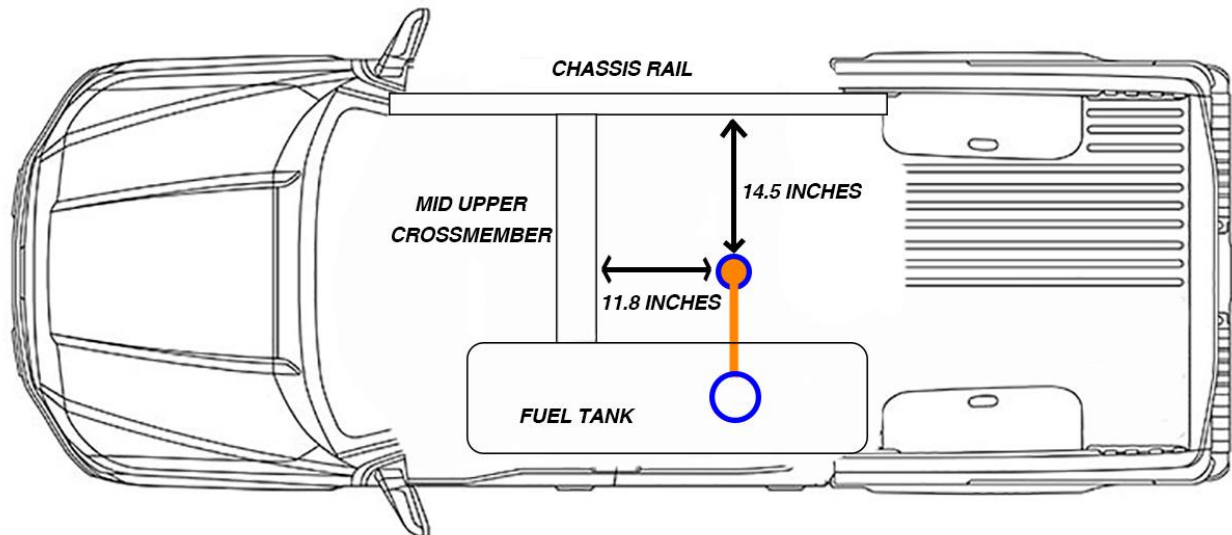

- 1) Measure 14.5 inches from the inside of the passenger side chassis rail and mark it.



- 2) Measure 11.8 inches from the mid upper cross member and mark it.



- 3) Find the intersection of these two points and mark it.



- 4) Drill a pilot hole from underneath vehicle

Inside vehicle

- 1) Back in the cabin where the pilot hole was drilled from underneath. Use a stepped drill bit or a hole saw to make a 30 mm hole.
- 2) Fit supplied grommet to hole with protruding side facing downward.
- 3) Feed wiring section F150-7 and F150-8 through grommet and underneath with the assembled Anderson connectors remaining inside the vehicle.
- 4) Connect the Grey Anderson to the black Anderson and the Deutsch connector on the previously routed F150-1.
The black EMF shield wires do not need to connect to anything on the NON PWM controlled kit.

Underneath Vehicle

- 1) Pull wiring through grommet and route towards fuel tank. mount supplied wiring clips as shown.



- 2) Assemble terminals into Anderson connectors and connect to fuel tank wiring section F150-3, also connecting F150-7.



Inside Vehicle

- 1) Secure Wiring throughout cabin and re assemble trim components

Calibration Notes

Now that the OE fuel pump driver module is no longer controlling the fuel pump the PCM will produce one or more DTC's that will need to be switched off in the engine calibration. The typical code will be P0627 Fuel pump A control circuit/open but depending on vehicle year model there may be others. This is completely normal operation of this system.

F150WIRE1500

Ford F150 2018-2025
Fuel Module Wiring

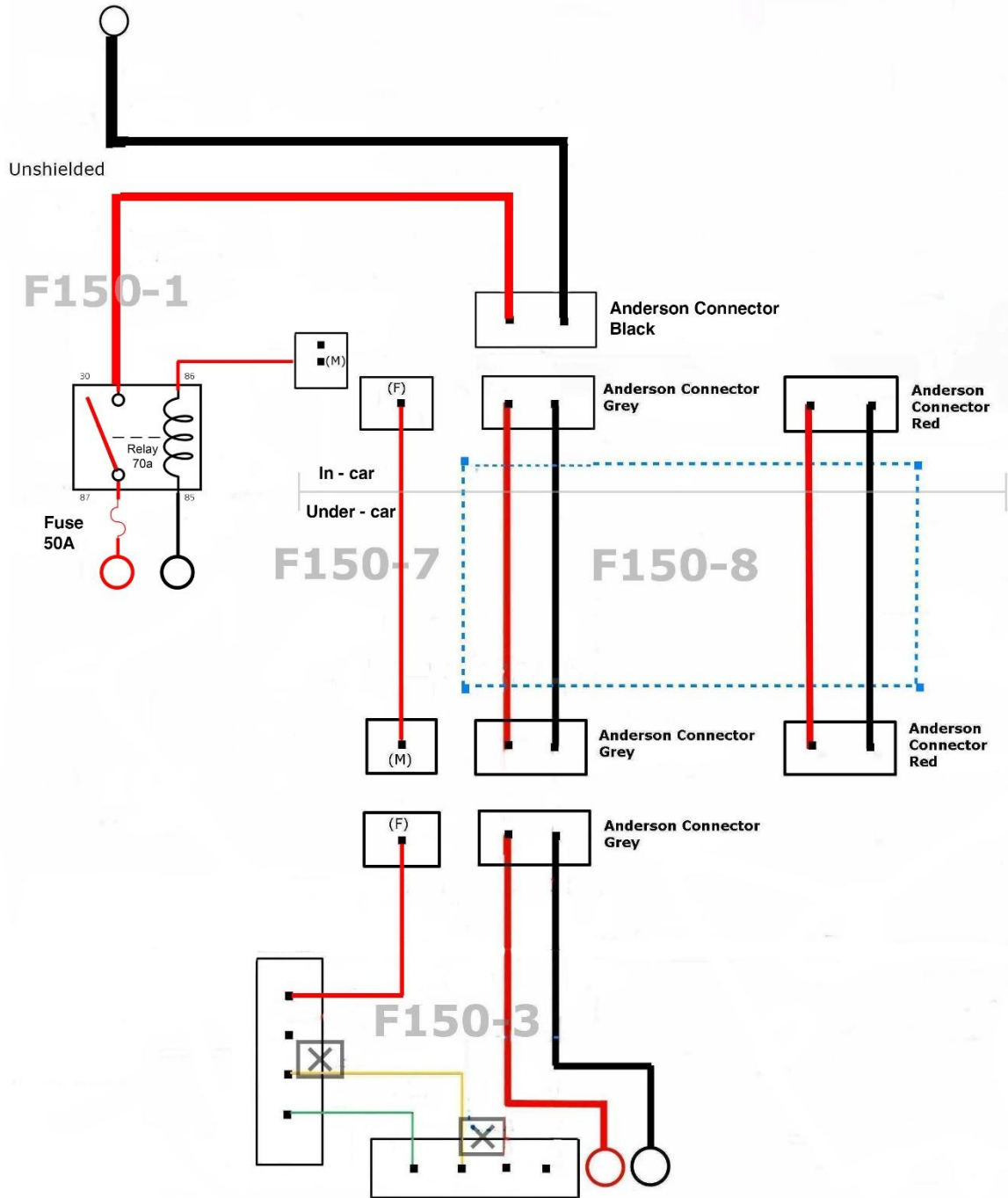

Engine start up

- 1) Refit the fuel pump fuse.
- 2) Reconnect your battery.
- 3) Ensure you have at least ½ tank of correct clean/fresh fuel.
- 4) Connect a fuel pressure gauge to the supply line at the fuel rail or read your fuel pressure on your scan tool.
- 5) Prime fuel system and start engine.
- 6) Check all fittings at pump and fuel rail for NO leaks
- 7) Stop engine and relieve fuel pressure.
- 8) Remove fuel pressure gauge and refit fuel line
- 9) Re-start engine and check for NO leaks.

IMPORTANT INFORMATION

Now that the OE fuel pump control is bypassed the PCM will produce one or more DTC's that will need to be switched off. KPM Fuel Systems strongly recommends that you have your engine tune checked by a professional tuning workshop!

Depending on the previous fuel system your vehicle has been tuned to, your car may run differently with the new KPM Fuel System pressure and extra supply.

This can cause rich or lean fuel mixtures and possibly be detrimental to your engine!

It is your responsibility to have your vehicle checked and/or re-tuned by specialist methods to ensure correct fueling and engine safety and reliability.

It is your responsibility to have your vehicle checked and/or re-tuned by specialist methods to ensure any fault codes in the vehicles electronic management system/s are corrected.