



**SRT Challenger, Charger, Demon 170 2022-2025**  
**PWM Fuel System Controller and Wiring**





## Important! Must Read First

Congratulations on the purchase of the KPM Fuel System PWM Fuel Controller for your [2022-2025 SRT Challenger, Charger, Demon170](#).

To ensure your KPM PWM Fuel System Controller is fitted correctly and operates perfectly and reliably we advise that this kit is to be fitted by a KPM Fuel Systems Dealer workshop.

If you are unable to access a KPM Fuel Systems dealer, we strongly recommend a professional and experienced fully qualified technician to install your new fuel system.

Ask your qualified installer to contact KPM Fuel Systems on any aspect not clear in the instructions provided.

Email: [support@kpmfuelsystems.com](mailto:support@kpmfuelsystems.com)

As a wide variety of skills, procedures, special tools, and workshop equipment is needed to install this kit:

- KPM will take NO responsibility or give NO guarantees on the operation of this product for fitment not carried out by a KPM Fuel Systems dealer or experienced qualified technician.
- KPM will take NO responsibility or give NO guarantees on the operation of this product due to not fitting this kit exactly as per the instructions provided.
- Ensure correct workshop safety procedures are carried out in fitment of this kit.
- Please read ALL instructions before commencing fitment

## Guarantee

On satisfaction that **ALL** instructions have been followed as per this document, KPM Fuel Systems will warrant this KPM PWM Fuel System Controller against any defects or faults for 12 months from the date of purchase.



## Operation and Functions

The KPM Pulse Width Modulated (PWM) Fuel System Controller has been specifically designed to support up to 80 amps of current draw continuously.

This gives it the capability of running up to 4x high flow Bosch motorsport fuel pumps simultaneously and continuously.

The controller is programmed to run the fuel system at a pre-determined fuel pressure. The fuel pumps will only be run at the duty cycle required and when required. This ensures less current draw, which means less heat, improved reliability and precise tune-ability.

With this amount of control over fuel flow, we now have the ability to support extreme horsepower with OE level functionality and legality.

The KPM Fuel System Controller is fully programmed from factory to perfectly suit all vehicle models and the many combinations of fuel delivery required.

The PWM Fuel System Controller has the following functions:

- 80-amp continuous current support
- Fully programmable to control up to 4 fuel pumps by means of one or all of the following inputs - Fuel pressure, MAP, MAF, Throttle position. \*
- Fully programmable OE factory PWM input, piggy back control.
- Fully programmable pump output and pump staging. \*
- Fully programmable system pressure settings. \*
- Multiple options for safety settings and pump control. \*
- Multiple gauge and warning light outputs. \*
- Advanced low temperature electronic circuits for robust motorsport and long-term reliability.
- Supplied with EMI shielded high amperage wiring and connector kit to block out interference with other vehicle electronic modules and devices.
- LED on controller for visual system pass and fault code readout.
- Fully modular fitment to all KPM Fuel Systems

\*For accessibility to re-program this function please contact KPM Fuel Systems.

The KPM PWM Fuel System Controller will be supplied pre-programmed to exactly suit the model of your vehicle and the level of KPM Fuel System you have purchased.

There is nothing else to do, just follow the wiring instructions, plug in the connectors and start the car. Simple!

The KPM Fuel Systems Fuel Controller will do the rest.



The KPM PWM Fuel System Controller comes complete with wiring to be connected to the vehicles factory Fuel Control Module (FPCM) to read the OE signals.

The KPM PWM Fuel System Controller uses the OE signals from the FPCM to calculate the correct current required to run the secondary pumps accordingly. The KPM PWM can also be programmed utilizing the OE fuel system programming tables.

## Operation

### OE– Primary Module only:

Primary module fuel pumps are controlled by a duty cycle input given out by the OE Fuel Pump Control Module (FPCM).

This duty cycle will vary on load demand. As an example, at idle both pumps may be running at approx. 40% duty cycle, at part load may be at 55% and then ramping up to full load at 80% duty cycle. This cycle will continue as load increases and decreases while keeping fuel pressure as per OE settings.

### KPM2200/2700 - Secondary Modules only:

On every start-up, the secondary module pump/s are primed for 10 seconds only. This ensures the circuit is tested and that the secondary module pump/s are always ready and primed when required for high load operation.

The OE FPCM will continue to run the primary module fuel pumps which are always running and duty cycle input will vary on load demand. As an example, at idle both pumps may be running at approx. 40% duty cycle, at part load they may be at 55%. When the primary module reaches 90% duty cycle, the KPM PWM Fuel System Controller will then turn on a duty cycle signal to the secondary module fuel pumps, and continue to ramp duty cycle up or down accordingly as load requires.

When load decreases and the KPM Fuel Controller sees the primary module returning to a duty cycle of only 80%, it will slowly ramp down the duty cycle signal to the secondary fuel module and eventually turn it off. This cycle will continue as load increases and decreases while keeping fuel pressure at a pressure controlled by the OE program.



## Important

This KPM PWM Fuel System Controller is engineered to operate perfectly as a complete system, when used with all components as supplied only by KPM Fuel Systems.

Depending on the level of KPM Fuel System you have purchased, included in the kit will be the following;

### **KPM 2200HP / 2700HP Fuel Systems**

- 1) KPM PWM Fuel System Controller - (for precise electronic control over fuel module operation)
  - 2) KPM Plug and Play EMI safe wiring kit (for correct, reliable and safe current supply)
- KPM Fuel Systems will take NO responsibility for the operation of this fuelsystem if any of the components listed are not utilized with this package.
  - KPM Fuel Systems will take NO responsibility for the operation of this fuel ssystem if any of the components listed are replaced with a non-KPM approved component.



## **Dismantle Vehicle for Fitment**

- 1) Remove the rear seat to access the rear seat floor.
- 2) Remove the trunk lining and surround trimming
- 3) Remove the battery cover to access the battery.

## **PWM Fuel Controller Mounting**

- 1) Place your PWM controller in the correct position on the centre front of the trunk cavity as pictured and while doing so use a marker pen to mark the 4 holes required for drilling.
- 2) Drill the 4 marked holes carefully with a 3.5mm drill bit and use the supplied screws to mount into position.
- 3) Be sure to mount the PWM controller small black earth wires/eyelet and screw down into one of the appropriate holes.

## **PWM Fuel System Controller Wiring**

- KPM 2200/2700HP utilizing the OE primary fuel module

- 1) You will need to follow the appropriate wiring diagram below.
- 2) All Anderson wiring connectors are color coded to ensure correct connection orientation as per wiring diagram.
- 3) Route the supplied wiring as per your specific fuel kit and as per appropriate wiring diagram and pictures listed below.

**\*Note – The KPM Fuel Systems PWM Fuel Controller wiring is made with a stainless-steel shielding incorporated. This is to prevent EMI (electro-magnetic interference) from disrupting other vehicle systems and control modules.**

**It is very important that the grounding wire connectors that link together every section of the supplied wiring are connected as per wiring diagram.**

## #CHAPWMWRE2700

### SRT Challenger, Charger, Demon 170 2022-2025 PWM and Wiring Schematic

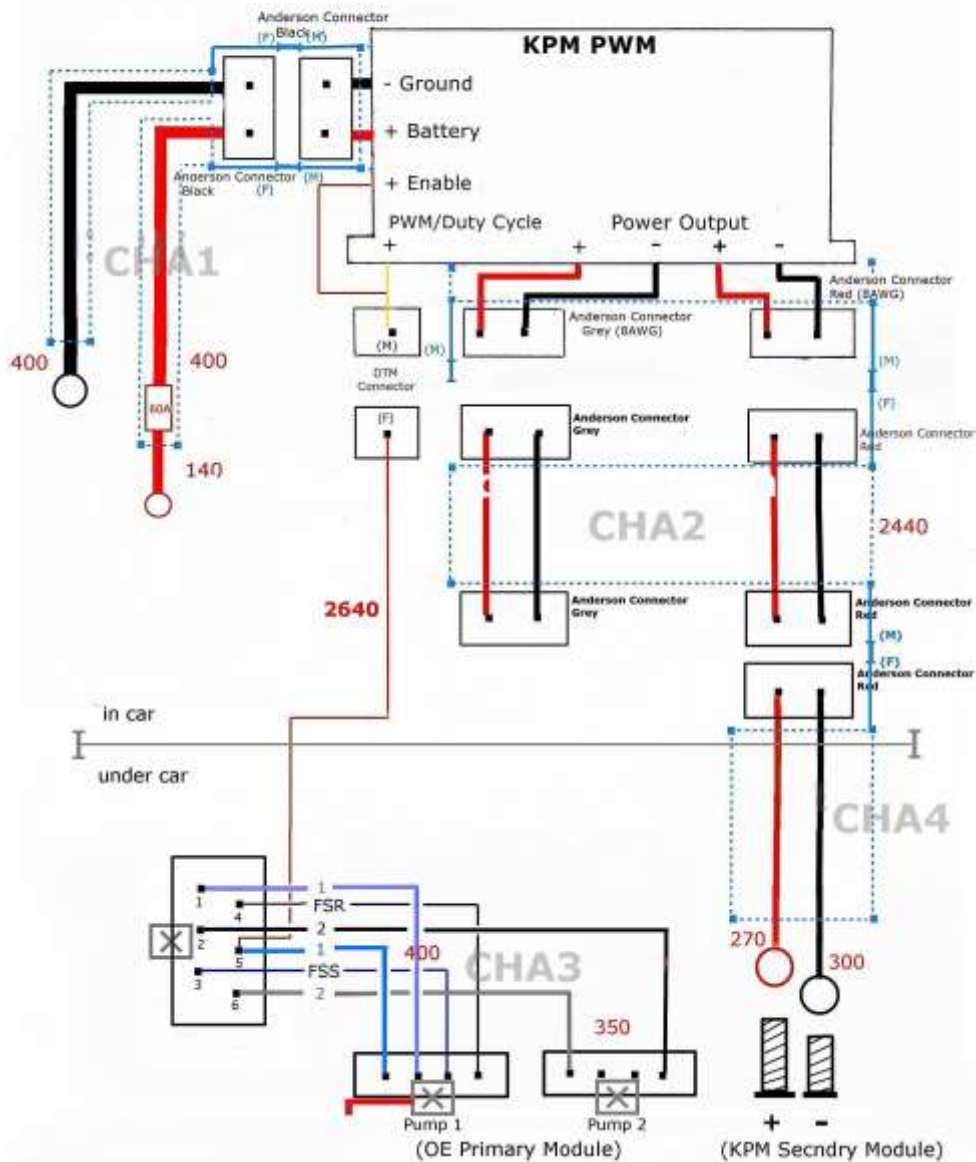



## Wire and Cable Routing

- KPM 2200HP / 2700HP **utilizing the OE primary fuel module**

Wiring kit- #CHA1, #CHA2, #CHA3, #CHA4

- 1) Connect the #CHA1 Black Anderson connectors together at the PWM.
- 2) Be sure to also connect the 2 small black grounding wires.
- 3) Route and connect the #CHA1 black wiring and eyelet to the grounding stud located at the RHF of the battery stud.
- 4) Route and connect the #CHA1 red wiring and fuse section to the power supply stud located at the fuse box towards the left hand rear of the battery. .
- 5) Mount the supplied fuse holder securely on an appropriate surface and secure the loom.
- 6) Connect #CHA2 wiring loom RED Anderson connector to the previously fitted #CHA4 wiring loom RED Anderson connector, coming from the tank primary fuel module at the LHR floor area. Be sure to also connect the small black ground wire.
- 7) Be sure to also connect the small black grounding wire.
- 8) Run #CHA2 wiring loom along the backseat floor towards the secondary fuel module area on the RHR floor area. Then continue to route towards the battery area in the trunk alongside the main red battery loom.
- 9) Connect the #CHA2 Red Anderson connectors together at the PWM.

## ECU Re-Calibration

The standard FPCM settings are set to run the fuel system at a maximum fuel pressure of 550 kPa. The KPM 2200HP and 2700HP fuel systems have been designed to supply maximum fuel at a pressure of 450 kPa.

To ensure you obtain the advertised maximum performance and supply from your KPM Fuel System we recommend running your new fuel system at the suggested pressure.

If preferred you can choose to retain the OE fuel pressure strategies. This may demand the system to run at much higher pressures which in turn may affect maximum advertised fuel delivery.

You will need to have a tuning professional re-calibrate your fuel pump controls as required.

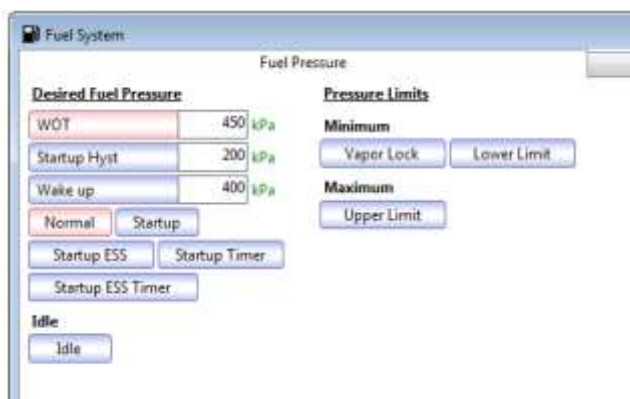

By setting these tables to 450 kPa the vehicles FPCMs will control the pressure lower to deliver the advertised flow rate from the Fuel system.

## Start Up and Checks

- 1) When you are satisfied your PWM Fuel Controller is fully installed, and you have re-calibrated your ECU, you are now ready to start your vehicle.
- 2) Simply start and run the car as normal.
- 3) On one end face of your KPM PWM Fuel System Controller you should see a green LED flashing approximately once per second. This means that all systems are working normally.

**Note\*** If your LED is not flashing green approximately once per second or is flashing any other color, you may have a system problem. Please contact KPM Fuel Systems.

## **Refit interior**

- 1) You can now refit your rear seat.
- 2) Refit the battery cover.
- 3) Refit your trunk floor and linings..

### **IMPORTANT INFORMATION**

**KPM strongly recommends that you have your engine tune checked by a professional tuning workshop!**

**Depending on the previous fuel system your vehicle has been tuned to, your car may run differently with the new KPM Fuel System pressure and extra supply.**

**This can cause rich or lean fuel mixtures and possibly be detrimental to your engine!**

**It is your responsibility to have your vehicle checked and/or re-tuned by specialist methods to ensure correct fueling and engine safety and reliability.**

**It is your responsibility to have your vehicle checked and/or re-tuned by specialist methods to ensure any fault codes in the vehicles electronic management system/s are corrected.**