

2018 Onwards S550/S650 Mustang GT

1500hp Fuel Module

PWM Fuel System Controller





Important! Must Read First

Congratulations on the purchase of a KPM Fuel System for your 2018 onwards S550/S650 Mustang GT.

To ensure your fuel system is fitted correctly and operates perfectly and reliably, we advise that this kit is fitted by a KPM Fuel Systems Dealer workshop.

If you are unable to access a KPM Fuel Systems dealer, we **strongly** recommend a professional and experienced fully qualified technician to install your new fuel system.

Ask your qualified installer to contact KPM Fuel Systems on any aspect unclear in the instructions provided.

Email: support@kpmfuelsystems.com

As a wide variety of skills, procedures, special tools, and workshop equipment is needed to install this kit:

- KPM will take NO responsibility or give NO guarantees on the operation of this product for fitment not carried out by a KPM Fuel Systems dealer or experienced qualified technician.
- KPM will take NO responsibility or give NO guarantees on the operation of this product due to not fitting this kit exactly as per the instructions provided.
- Ensure correct workshop safety procedures are carried out in fitment of this kit.
- Please read **ALL** instructions before commencing fitment

Guarantee

On satisfaction that **ALL** instructions have been followed as per this document KPM will warrant this KPM Fuel System against any defects or faults for 12 months from the date of purchase.

Operation and Functions

The KPM Pulse Width Modulated (PWM) Fuel System Controller has been specifically designed to support up to 80 amps of continuous current draw.

This gives it the capability of running up to 4x high flow motorsport fuel pumps simultaneously and continuously.

The controller is programmed to run the fuel system at a pre-determined fuel pressure. The fuel pumps will only be run at the duty cycle required and when required. This ensures less current draw, which means less heat, improved reliability and precise tune-ability.

With this amount of control over fuel flow, we now have the ability to support extreme horsepower with OE level functionality.

The KPM PWM Fuel System Controller is fully programmed from factory to perfectly suit all vehicle models and the many combinations of fuel delivery required.

The PWM Fuel System Controller has the following functions:

- 80-amp continuous current support.
- Fully programmable to control up to 4 fuel pumps by means of one or all of the following inputs
 - Fuel Pressure, MAP, MAF & Throttle position *
- Fully programmable OE factory PWM input, piggy back control.
- Fully programmable pump output and pump staging. *
- Fully programmable system pressure settings. *
- Multiple options for safety settings and pump control. *
- Multiple gauge and warning light outputs. *
- Advanced low temperature electronic circuits for robust motorsport and long-term reliability.
- Supplied with EMI shielded high amperage wiring and connector kit to block out interference with other vehicle electronic modules and devices.
- LED on controller for visual system pass and fault code readout.
- Fully modular fitment to all KPM Fuel Systems

[* To re-program this function please contact KPM Fuel Systems.](#)

The KPM PWM Fuel System Controller will be supplied pre-programmed to exactly suit the model of your vehicle and the level of KPM fuel system purchased.

There is nothing to do, just follow the wiring instructions, plug in the connectors and start the car. Simple! The controller will do the rest.



Vehicle and fuel system specific operation and function

Vehicles [with](#) a Factory FPCM Fuel Pump Control Module (Mustang GT 2018 onwards)

The KPM PWM Fuel Module Controller comes complete with wiring to be connected to the vehicles factory FPCM to read the OE signals. The KPM PWM Fuel System Controller uses the OE signals from the FPCM to calculate the correct current required to run the pumps accordingly.

The KPM PWM Fuel Controller can also be programmed utilizing the OE fuel system programming tables.

KPM1500 Fuel System – Primary Module only

Primary module fuel pumps are always running and duty cycle input will vary on load demand. As an example, at idle both the pumps may be running at approx. 40% duty cycle and at part load they may be at 55% and then ramping up to full load at 80% duty cycle.

This cycle will continue as load [increases](#) and [decreases](#) while keeping fuel pressure at a constant pre-programmed 448 kPa.

KPM2200/2700 Fuel System- Primary and Secondary Module

On every start-up, the secondary module pumps are primed for 10 seconds only. This ensures the circuit is tested and that the secondary module pumps are always ready and primed when required for high load operation.

Primary module fuel pumps are always running and duty cycle input will vary on load demand. As an example, at idle both the pumps may be running at approx. 40% duty cycle and at part load they may be at 55%.

When the primary module reaches 90% duty cycle, the fuel controller will then turn on a *duty cycle signal* to the secondary module fuel pump and continue to ramp duty cycle up or down accordingly as required.

When load decreases and the controller see's the primary module requiring a duty cycle of only 80% it will then slowly ramp down the *duty cycle signal* to the secondary module and eventually turn it off.

This cycle will continue as load [increase](#) and [decreases](#) while keeping fuel pressure at a constant OE programmed 448 kPa.



Important

This fuel system is engineered to operate perfectly as a complete system, when used with all components as supplied only by KPM Fuel Systems.

Depending on the level of KPM Fuel System you have purchased, included in the kit will be the following;

- 1) KPM PWM Fuel System Controller - (for precise electronic control over fuel module/s operation)
 - 2) KPM Plug and Play EMI safe wiring kit (for correct, reliable and safe current supply).
- KPM Fuel Systems will take NO responsibility for the operation of this fuelsystem if any of the components listed are not utilized with this package.
 - KPM Fuel Systems will take NO responsibility for the operation of this fuel system if any of the components listed are replaced with a non-KPM approved component.

Before Dismantling

- You will need to reduce residual fuel pressure in the fuel system to 0 kPa to enable disconnection of fuel lines.
- You can do this by removing the fuel pump fuse and running the engine until fuel pressure drops to 0 kPa.
- Disconnect the Battery.

Standard Fuel Module Removal

- 1) Drain the fuel tank.
- 2) Mustang GT- the fuel module can be accessed by a rubber grommet cover under the LH rear seat. Carefully remove the fuel lines from the fuel module (a quick disconnect tool is recommended for disconnecting fuel lines, take extra care in not crimping/damaging the fuel line on removal).
- 3) Remove the electrical connector from the module.
- 4) Unscrew the retaining ring holding the module to the tank with the correct tool.
- 5) Lift the module from the tank until you can access and remove the crossover pipe connector at the base of the canister.
- 6) Carefully lift the module completely from the fuel tank.

Fitting kit revision 130525

If you have part #MUSXPIPEADAPT in your fitting kit “as pictured below” **USE THIS PART.**



The right angle quick connect fitting “as pictured below” and ear clamp can be disregarded.



KPM Primary Fuel Module Fitment 800HP/1000HP

You will need to remove the fuel sender unit from the standard fuel module for fitment to the upgraded KPM Fuel Module.

- 1) Attach the fuel tank crossover connector #MUSXPIPEADAPT to the fuel module canister.



- 2) Carefully lower the fuel module into the fuel tank.



- 3) With the fuel pump module sitting in the tank, slide it toward the rear of the opening to allow access for the sender unit to be placed in.



- 4) Lower sender unit into available space alongside the bracket.



- 5) Plug the sender unit connector into the lid next to the fuel pump connector and then slide the sender unit base up the bracket and clip into position. Ensure wires are clipped into bracket.



- 6) Ensure tank O ring and sealing surfaces are clean of debris. Compress fuel pump module lid and attach retaining ring. Use suitable tool to lock retaining ring.
- 7) Re fit fuel line and electrical connector.
- 8) Start engine and check for leaks.
- 9) Refit the rubber floor grommet and rear seat base.

Dismantle vehicle for fitment

- 1) Remove the RHF wheel.
- 2) Remove the RHF inner fender trim by removing the 5 hold down clips.



- 3) Remove the RH front seat.
- 4) Remove the RH footwell panel.
- 5) Remove the RH inner sill panel trimming.



6) Pull back the RH footwell carpet



- 7) Remove the rear seat base.
 - 8) Remove RH rear inner cabin panel.
- **If the vehicle has already** been fitted with a KPM Fuel Module, you can disconnect the wiring at the fuel module by unplugging the grey Anderson connectors.
 - a. Proceed to remove and discard the rest of the previous KPM wiring and relay that leads to the battery (this will be replaced with the new #MUS41 wiring section supplied)
 - **If the vehicle is now** being fitted with the KPM Fuel Module/s you will need to read the separate instruction section on the relevant [KPM Fuel Module Fitment](#).

PWM Fuel Controller Mounting

- 1) Place your PWM controller just below the RH rear $\frac{1}{4}$ window with the cables facing downwards as pictured.
- 2) Use a marker pen to mark the 4 holes required for drilling.
- 3) Drill the 4 marked holes carefully with a 3.5mm drill bit and use the supplied screws to mount into position.
- 4) Be sure to mount the PWM controller small black earth wire/eyelet and screw down into one of the appropriate holes.



- 5) You will need to remove the insulator from the RH rear inner cabin panel and mark out for cutting as shown.



- 6) Test fit and check the trim panel and foam insulator fits correctly over the PWM.
- 7) Final fit the foam insulator with the hold down clip and hot glue on one side and totally hot glue the other side of the insulator back onto the trim panel.

PWM Fuel Controller Wiring

- 1) Depending on the level of KPM Fuel System you have installed – either [KPM1500 HP](#), [KPM2200 HP](#) or [KPM2700 HP](#) you will need to follow the appropriate wiring diagram below.
- 2) All Anderson wiring connectors are color coded to ensure correct connection orientation as per wiring diagram.
- 3) Route the supplied wiring as per your specific fuel kit and as per appropriate wiring diagram and pictures listed below.

*Note – The PWM Fuel controller wiring is made with a stainless-steel shielding incorporated. This is to prevent EMI (electro-magnetic interference) from disrupting other vehicle systems and control modules. It is very important that the grounding wire connectors that link together every section of the supplied wiring are connected as per wiring diagram.

S650 only Factory FPCM Bypass Installation

To ensure the [S650 Mustang](#) factory fuel pump control module (FPCM) reads the correct signals and does not turn on the engine check light, KPM have supplied a Fuel Pump Monitor Generator (FPMG) to be installed.

- 1) Disconnect the factory wiring connector at the FPCM located under the rear seat base on the LHS floor area.
- 2) Connect the #MUS16 (FPMG) male connector to the factory wiring connector.
- 3) Connect the #MUS16 (FPMG) female connector to the (FPCM).

See (FPMG) wiring diagram below

#FPMG-MUS

S650 Mustang 2024 Onwards
Fuel Pump Monitor Generator

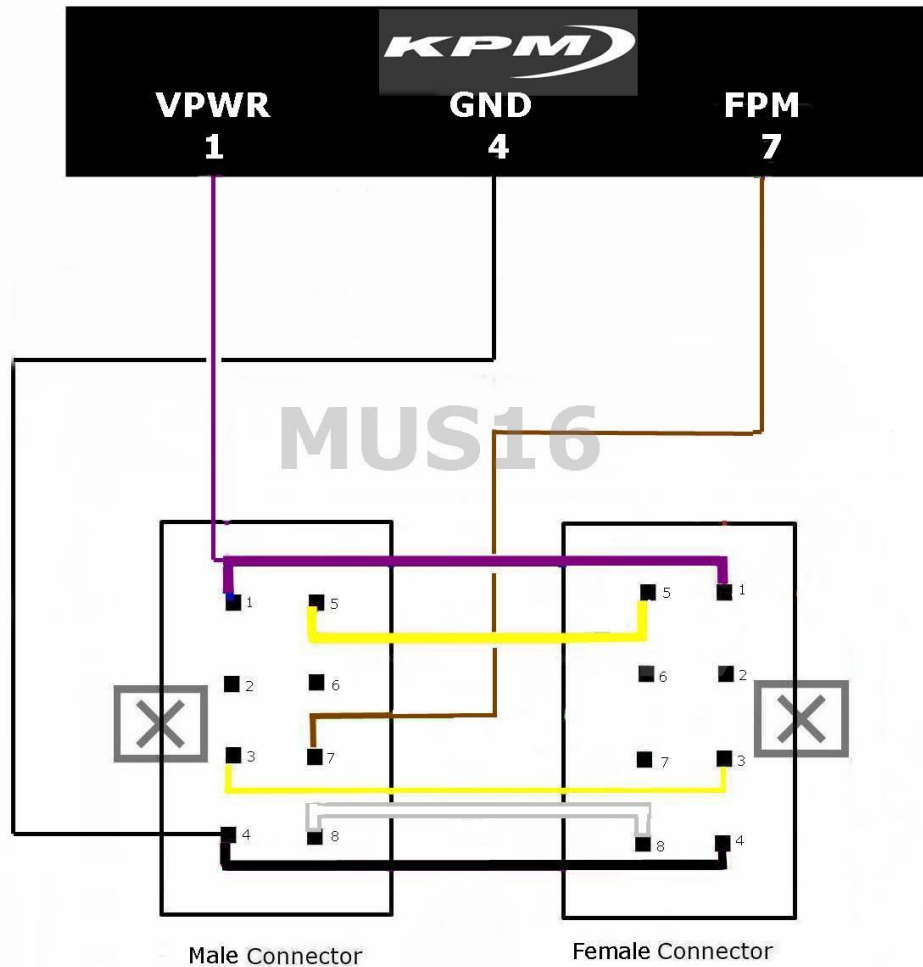

PWM 1500 HP

Mustang GT S550/S650 PWM and Fuel Module Wiring

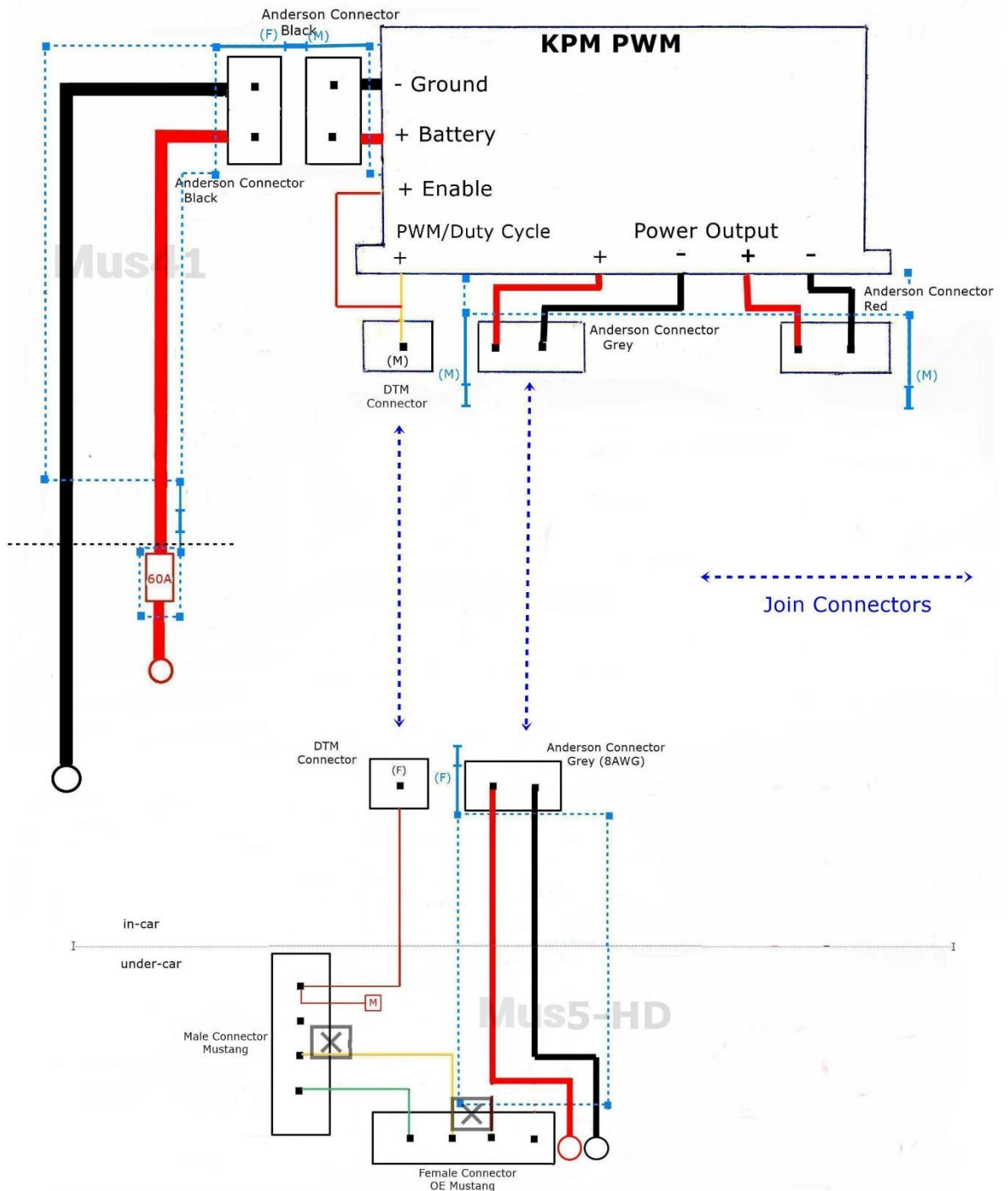

PWM 2200/2700HP Mustang GT S550/S650 PWM and Fuel Module Wiring

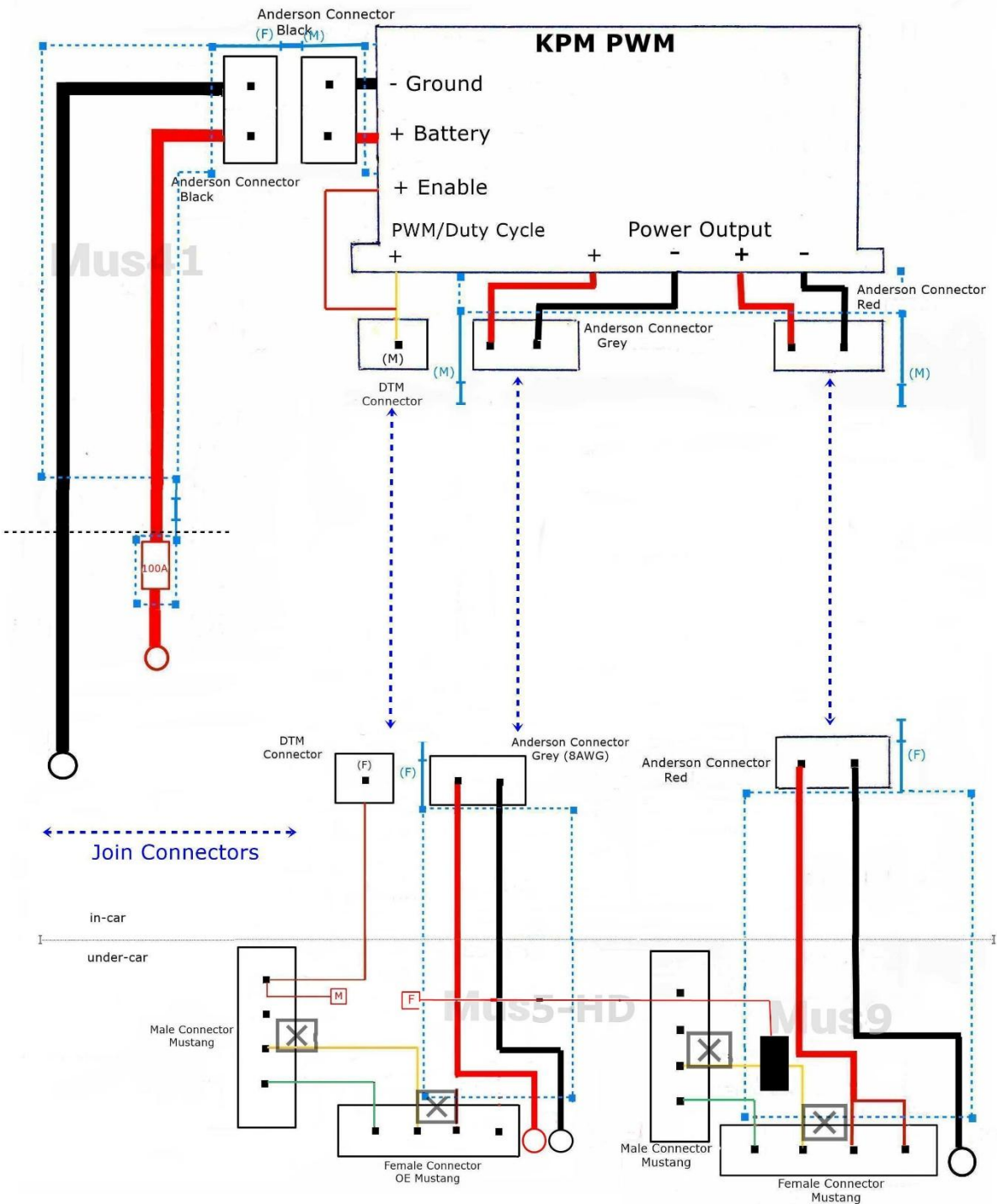

Wire and cable routing

- 1) Remove the black Anderson connector surround from the #Mus41 wiring loom end.
- 2) From under the hood and using a tracer wire/tool, feed the #Mus41 wiring loom through the hole above the RH chassis rail area below the battery and out the hole into the RH inner fender cavity area.



- 3) Pull most of the #Mus41 wiring loom through the chassis hole onto the ground, while leaving enough length under the hood to comfortably connect the other end to the battery.
- 4) Mount the new fuse section in the battery box area in an appropriate position to clear the battery.
- 5) Make a small incision into the rubber grommet located in the inner fender cavity and feed the #Mus41 wiring loom through the rubber grommet into the RH footwell and floor area.

- 6) You may need to lubricate the wiring loom with some silicone spray to ensure it slides through the grommet easily.



- 7) You will now have the majority of the orange cable (Mus41) inside the cabin ready to route to the PWM fuel controller.

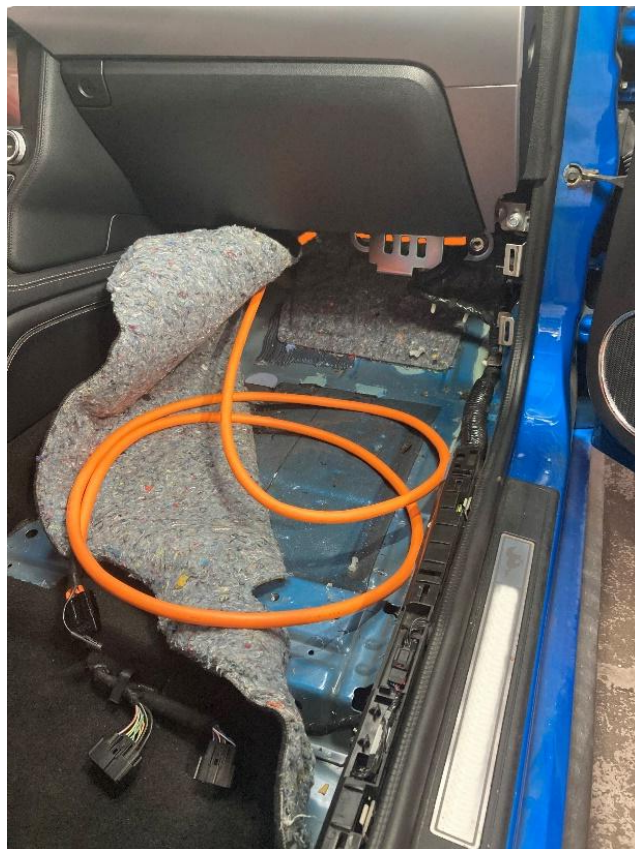

- 8) Continue to route the #Mus41 loom from the footwell along the RH sill panel alongside the existing OE loom towards the PWM.



- 9) Connect the black Anderson connector on cable (Mus41) to the black Anderson connector on the PWM.



10) Remove your primary (OE) fuel pump grommet cover and drill a 30mm hole as shown.



11) Fit the new supplied 30mm grommet as shown.



- 12) Remove the grey Anderson connector surround from the primary module cable (Mus5) and feed the cable through the new grommet.

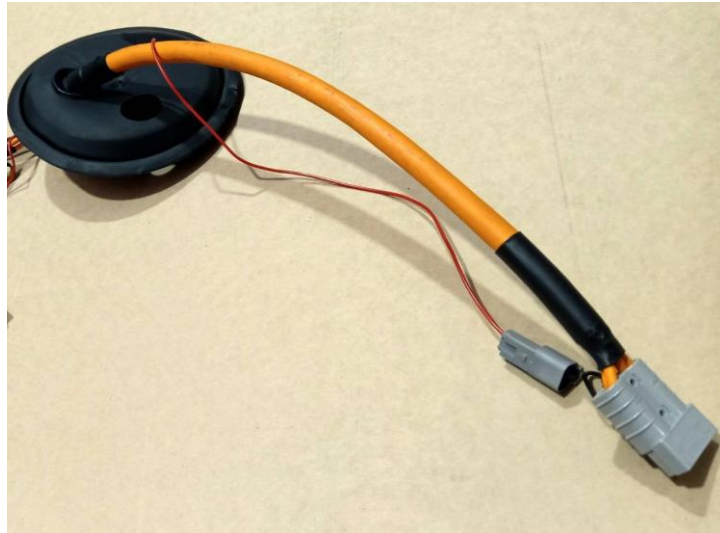

- 13) Connect all the primary fuel module connectors as per the wiring diagram. Be sure to securely tension the earth cable eyelet to the pump.



- 14) Refit the grey Anderson connector surround and route neatly towards the PWM. Connect to the grey Anderson connector on the PWM.

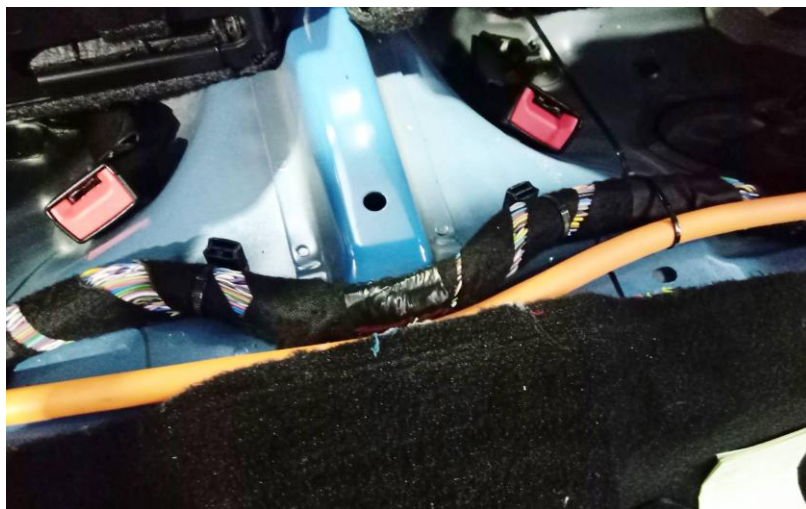

- 15) If you are fitting a secondary fuel module for a 2200HP or 2700HP KPM fuel system, locate the fuel module grommet cover on the RH rear seat floor and repeat all the steps 10 to 14 utilizing the (Mus9) cable and connecting the red Anderson connectors to the PWM.



- 16) You can now go along the cable/s and tidy up and neaten the inside cabin fitment with cable ties securely alongside existing looms and fittings.
- 17) Refit the RHF wheel.
- 18) Refit the RHF inner fender trim

Start Up and Checks

- 1) When you are satisfied your PWM Fuel Controller is fully installed, you are now ready to start your vehicle.
- 2) Simply start and run the car as normal.
- 3) On one end face of your KPM PWM Fuel System Controller you should see a green LED flashing approximately once per second. This means that all systems are working normally.

Note* If your LED is not flashing green approximately once per second or is flashing any other color, you may have a system problem. Please contact KPM Fuel Systems.

Refit interior

- 1) Refit all your interior sill panel trimmings.
- 2) Refit you modified rear trim panel.
- 3) Refit your footwell panel.
- 4) Refit your RH footwell carpet.
- 5) Rear fit your front seat.
- 6) Refit your rear seat base.
- 7) You may need to cut the underside plastic section of your rear seat base as pictures to allow room for the new wire sections.



Congratulations, you have successfully fit the KPM PWM Fuel System Controller.

IMPORTANT INFORMATION

KPM strongly recommends that you have your engine tune checked by a professional tuning workshop!

Replacement of any fuel system can cause rich or lean fuel mixtures and possibly be detrimental to your engine!

It is your responsibility to have your vehicle checked by specialist methods to ensure correct fueling and engine safety and reliability.

It is your responsibility to have your vehicle checked by specialist methods to ensure any fault codes in the vehicles electronic management system/s are corrected.